



uVicky-10 Macro Vickers Hardness Tester

Instruction Manual



Anhui Mikrosize Precision Instrument Co.,Ltd

Add: A-4035 RuiFeng Business Expo, Wuhu City, China, 241000.

Web: www.mikrosize.com **Email:** mikrosize@mikrosize.com

Contents

1.Main Description	1
2.Technical Specifications	1
3.Installations and Regulation(Debugging)	3
3.1.Operational Conditions	3
3.2.Unpacking and Installation.....	3
3.3.Operator panel and menu description	5
3.4.Usage of the hardness tester	9
3.5.Calibration of hardness value	12
3.6.Calibration of test force	13
3.7.Maintenance and precautions of hardness tester.....	13
4.Accessories(Packing List).....	16

1.Main Description

The hardness tester is suitable for measuring the micro hardness of micro, thin, surface coating specimens, and determination of glass, ceramics, agate, artificial gemstones such as more brittle and hard materials Knoop hardness. It is an ideal hardness testing instrument for scientific research institutions, enterprises and quality inspection departments to study and test .

2.Technical Specifications

- 2.1 Touch screen interface, easy to operate;
- 2.2 Boot that is used, no need to install the weight, no need to install and debug;
- 2.3 Electric loading, closed loop control;
- 2.4 Indenter and objective can shift automatically, the test point is automatically positioned accurately
- 2.5 Hardness value can be calibrated by scales or standard blocks
- 2.6 The test force is automatically corrected and the force accuracy is increased by an order of magnitude
- 2.7 Test data saved forever for database query;
- 2.8 Chinese and English language
- 2.9 Twin objectives to test, increase the testing range
- 2.10 Modular design, easy maintenance;

2. Technical Specifications

2.11 Hardness value conversion according to the standard ASTM

2.12 Software is available to connect to the computer, computer can control the hardness tester, can edit images and data, can update to semi-automatic Vickers hardness tester.

2.13 Nine test force: 0.1kgf (0.98N)、 0.3kgf (2.94N)、 0.5kgf (4.9N)、 1.0kgf (9.8N)、 2.0(19.6N)、 2.5kgf(24.5N)3.0kgf (29.4N)、 5.0kgf (49.0N)、 10kgf (98.0N)

2.14 The magnification of the microscope: 200×, 100×

2.15 Hardness test range: 8HV~2900HV

2.16 Minimum detection unit: 0.01μm

2.17 Tester force duration time: 0 ~ 99s

2.18 Maximum height of specimen: 180mm

2.19 Distance from indenter center to outer wall: 160mm

2.20 Weight of the main hardness tester: about 55Kg

2.21 Power Supply: AC220V/50Hz

2.22. Exterior dimension: (600×220×700)mm

3.Installations and Regulation(Debugging)

3.1 Operational Conditions

- 3.1.1 Room temperature 10 to 35°C;
- 3.1.2 Installed in a horizontal position on a solid basement;
- 3.1.3 In an environment without any shock or vibration;
- 3.1.4 In a surrounding without any corroding agent;
- 3.1.5 Room relative humidity less than or equal to 65%.

3.2 Unpacking and installation

- 3.2.1 Remove the outer packing box, lift the box, take out the accessory box.
- 3.2.2 Raise the bottom plate, with the wrench unscrewed the two M10 bolt under the floor,the hardness tester and the bottom plate are separated, take out the hardness tester (pay attention to safety).
- 3.2.3 Put the hardness tester on the stable working table.At the same time, open hole on the proper position of the working platform(Fig.1),make the screw work normally.
- 3.2.4 Remove the adjustment screw (1) from the accessory case and screw it to the bottom of the main body (Fig. 2) and transferred to the level.
- 3.2.5 Turn the wheel(2)make the screw (3) down smoothly through the work table opened hole.The specific size of the hole is:

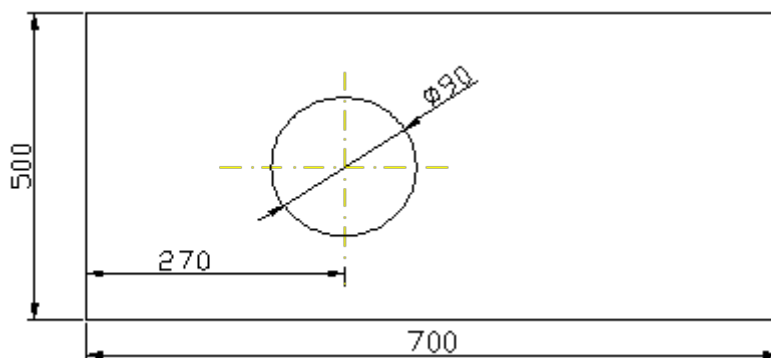

(Fig 1)

3.Installations and Regulation(Debugging)

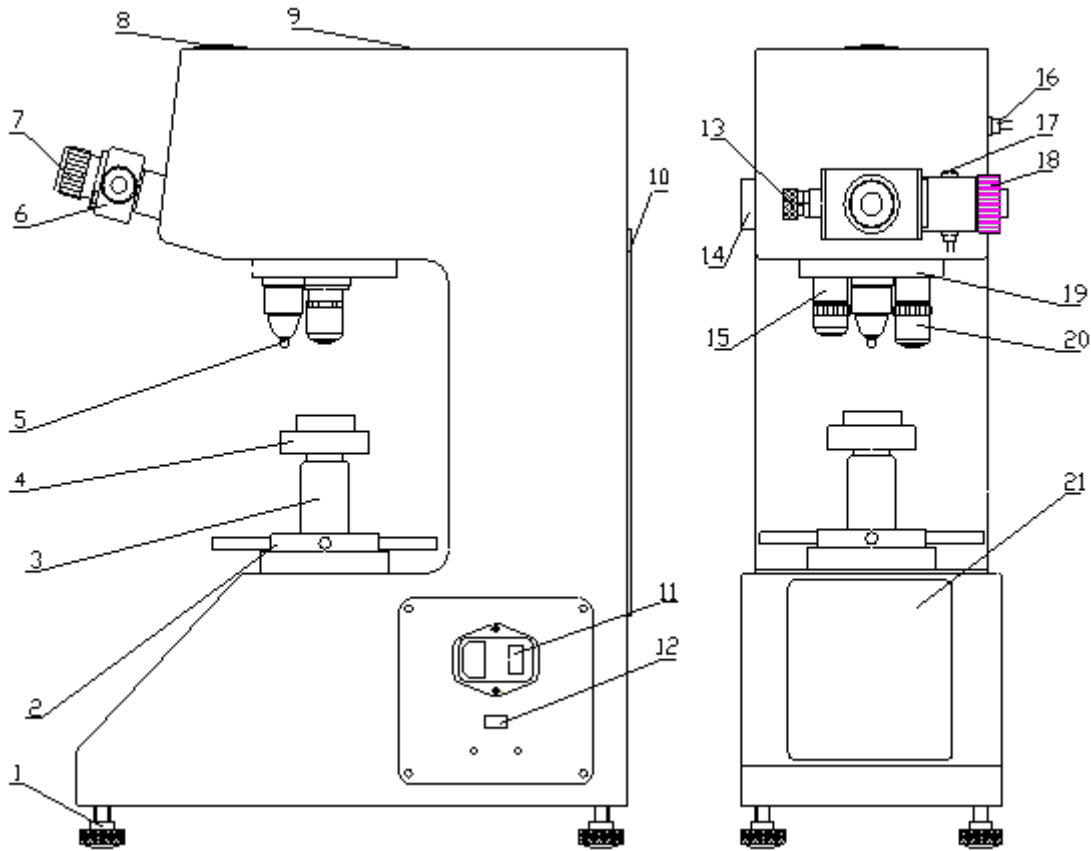

(Fig 2)

1.Adjusting screw	8.Camera cover plate	15.20×Objective
2.Wheel	9.The Upper Cover	16.Eyepiece socket
3.Lifting Screw(protection cover)	10.The Back Cover	17.Measuring button
4.Testing Table	11.Power Socket and Switch	18.The Right Drum Wheel
5.Indenter	12.U disk Socket	19.Turret
6.Micrometer eyepiece	13.The Left Drum Wheel	20.10×Objective
7.Eye Patch	14.Light source	21.Touch screen

3.2.6 Remove the test stand (4) from the accessory box and place it in the hole of the screw(3) Insert one end of eyepiece (6) into the hole of eyepiece tube and make sure it is fixed at the bottom. The eyepiece wire plug is inserted in the eyepiece socket (16).

3.Installations and Regulation(Debugging)

3.3 Operator panel and menu description

3.3.1 Connect the power cord and turn on the power switch(11),then plug in U disk,Operation interface open(fig.3).

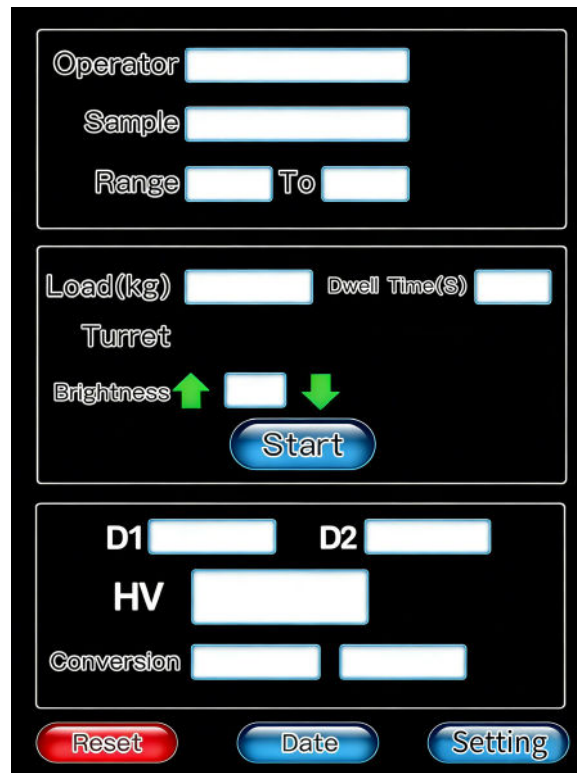

(Fig 3)

Tester, sample name, qualification range, stress, dwell time, conversion”Those text box on the right side of the text is clicked for information entry. The operation method is as follows: the single point with finger and entered into the corresponding input interface.

3.3.2 Information input

3.3.2.1 Input Operator and Sample

Click the textbox to the right of “Operator”and” Sample”. Then pop out a keyboard in the screen. Input the name of “Operator” and “Sample”, and click “OK”. If don’t want to change the name that already exists on the screen,click “ESC”. As shown in fig 4:

3.Installations and Regulation(Debugging)



(Fig 4)

3.3.2.2. Method of inputing Tolerance and Dwell time

Click the textbox to the right of "Tolerance" and " Dwell time". Then input the number as shown in fig.5 . And click "OK". If want to cancel, click "ESC".

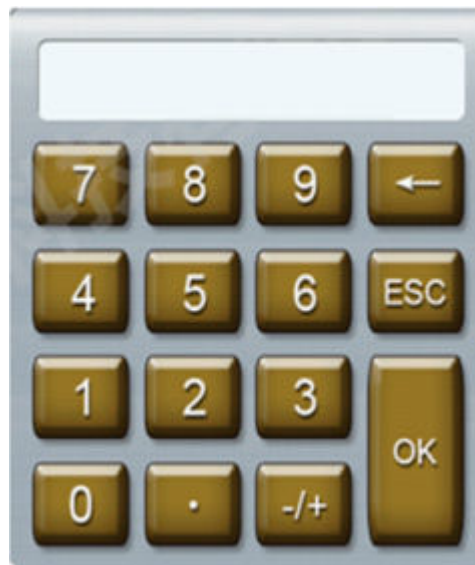

(Fig 5)

3.3.2.4 Test force selection

Click" " on the right side of force type and choose the force. Click on test force as shown in fig 6

3.Installations and Regulation(Debugging)

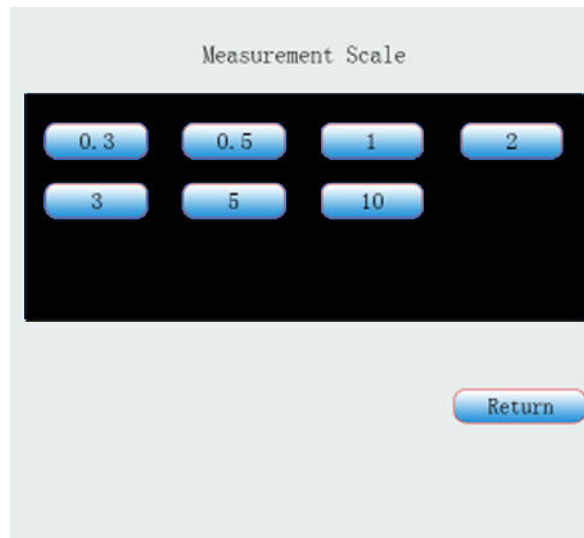

(Fig 6)

3.3.2.5. Choose dwell time. Click the on right side of Dwell time to select dwell time. If there is no need to modify, click Return back to main interface.

3.3.2.6. Click up and down arrow keys(↑, ↓) to adjust lightness.

3.3.2.7. Click"Conversion"and choose the scale. If there is no need to modify, click Return().As shown in fig. 7:

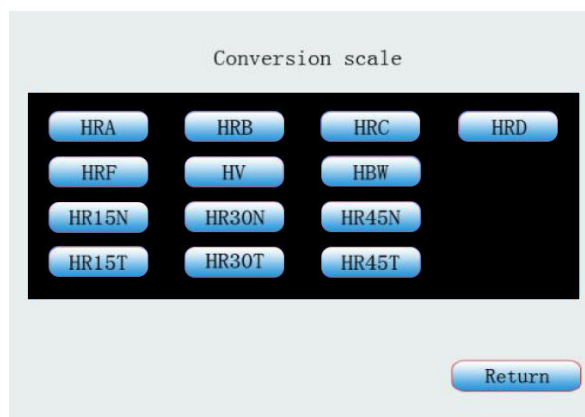

(Fig 7)

3.3.2.8 Click"Data", shows data processing menu: hardness type, hardness value, conversion type,conversion value, maximum, minimum, average and variance value.Totally save 20 test points,will auto delete first point when exceed 20 points, always keep 20 test points. Click"Return"

3.Installations and Regulation(Debugging)

NO.	Hardness-S	Hardness-V	Conversion-S	Conversion-V

Last Next Clean Statistical

MAX	MIN	AVE	VAR

Empty Return

(Fig 8)

3.3.2.9 Language selection

3.3.2.9.1 Click "Setting", pop out menu. As shown in fig 9:



Testing force calibration
should only be operated under
help of professional personnel.

Password:

Enter Return

(Fig 9)

3.3.2.9.2 Click "", pop out numeric keypad, input 12345678, click "Enter", pop out interface as shown fig 10:

3.Installations and Regulation(Debugging)

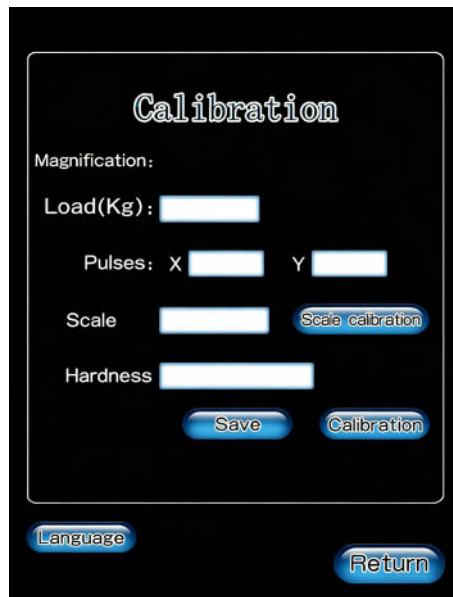

(Fig 10)

3.3.2.9.3 Click ,Chinese-English shift,click , go back to the main interface.

3.4 Usage of the hardness tester

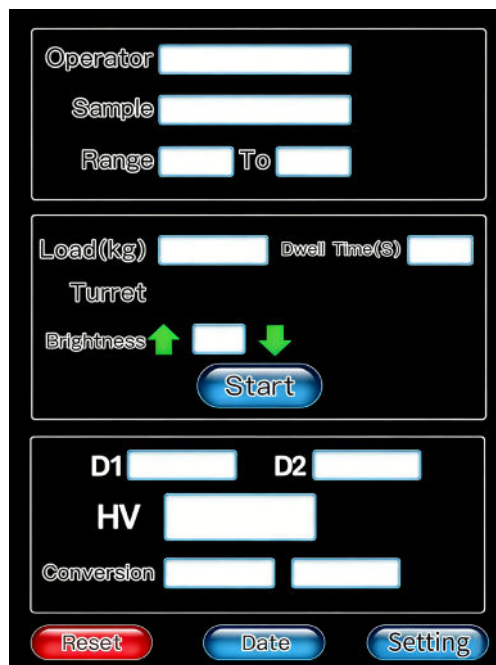

(Fig 11)

3.4.1 For example:test 10kgf scale

3.4.1.1 Click loads on the screen ,click10

3. Installations and Regulation (Debugging)

3.4.1.2 Click dwell time input 10s, click OK.

3.4.1.3 Click , indenter(5) turn to the front position.

3.4.2 Place the standard block or test piece on the test table(4), Rotation The wheel(2) make test table rise. When the distance between test piece, the lower end and the indenter is about 0.5~1mm, press 20X, 20X objective(20) turn to front. At this time, the general magnification of light path system is 200×. Put eyes close to the Eyepiece (6) to observe. When a bright spot appears to the vision field in Eyepiece (6), it shows the focusing plane will come closely. At this time, raise the Test Table up slowly and slightly until the surface of specimen forms a clear image, at this point, the focusing process is completed. If can not find the specimen's focal plane, turn the 10X objective to the front position, at this time, the general magnification is 100X, it is easy to find the focal plane after reducing the magnification.

3.4.3 Press "start" button, the indenter automatically comes forward and test force is applied, "↓" appears on screen which shows the test force is loading. "DWELL" means to keep the test force. When loading and unloading of test force is completed, the indenter back to its origin position, and turn the 20× Objective(20) to front, the main screen will back to operating page.

Caution: If choose 10X objective to test, click 10X, 10x objective(15) turn to the front to test.

3.4.4 Indentation can be seen in the micrometer eyepiece field of view, then you can measure the indentation diagonal's length in the micrometer eyepiece. If the indentation is not clear, you can slowly turn the rotary wheel (2), move up and down the test sets (4) till the image of the Indentation is the clearest. If two graduated lines seem vague in the Eyepiece, adjust the Eye Guard (7) till the graduated lines are the clearest, this is according to personal vision.

3.Installations and Regulation(Debugging)

3.4.5 Rotate the Right Drum Wheel (17) to move the graduated line of eyepiece, enable two graduated lines to be close. When inner side of two graduated lines are closely without limit (the inner side of graduated lines reach critical state with no space between them to allow the light penetrate, but two graduated lines are prohibited to overlap each other), press "Reset", at this time, the d1: 0000 value on the main screen is zero(FIG.12), at the zero position for technique term. Now the length of diagonal line of indentation can be measured in the Eyepiece.

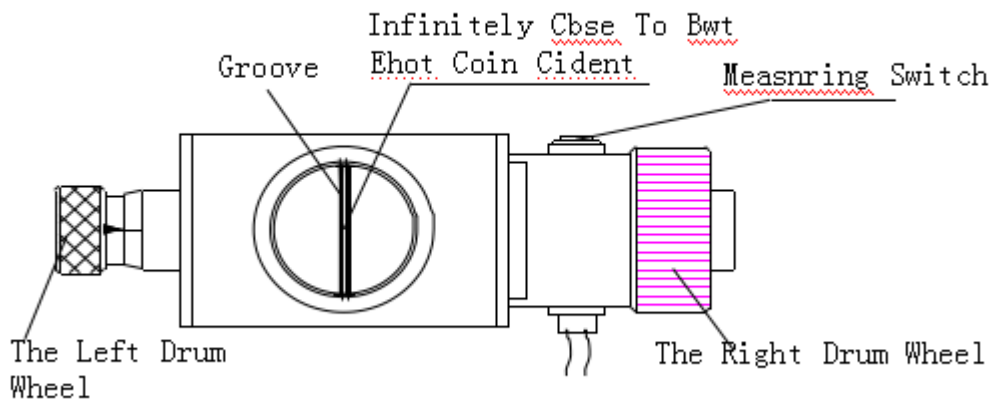

(Fig 12)

3.4.6 Rotate the Right Drum Wheel(17)to let graduated lines separate each other, turn the Left Drum Wheel(12)to move the left graduated line until it's inner side tangent to the intersecting point at left outside of the indentation, and then move the right graduated line until it's inner side tangent to the intersecting point at right outside of indentation(Fig13).

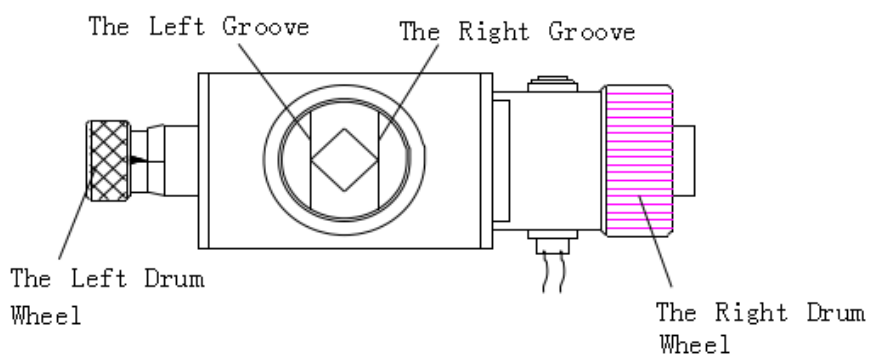

(Fig 13)

3.Installations and Regulation(Debugging)

After measurement, press the measuring button, the measurement of length d1 of the diagonal is completed; turn micrometer eyepiece (6)90. Use the above methods to measure the diagonal length of the d2, press the measuring button (16).At this time, the screen shows testing display value and exchanged hardness display value measured at present time. If the correctness of the measurement is not sure, you can repeat measuring again as methods described above.

3.5.Calibration of hardness value

3.5.1 The precision of the hardness displaying value of the hardness tester is just calibrated before the instrument is turned out of the factory.If an error is caused due to the transportation or according to the various requirements of the client, the hardness value may be revised by pressing input keys.The method is as following: Load on a hardness block, then click" Calibrate",turns out Fig 14.



(Fig 14)

3.Installations and Regulation(Debugging)

3.5.2 Click the text box to input 12345678, click“Enter”,turns out Fig 15.



(Fig 15)

3.5.3 Click Hardness ,input the standard block's hardness value in the numeric keypad, then measure the indentation, click the start button, the measurement of diagonal d1 is completed. Turn the objective to 90°, measure the length of diagonal d2 as the above way, after measurement, click save, the hardness is finished calibration. Click return to go back to the main interface.

3.6.Calibration for test force

Test force is calibrated before the instrument turned out of the factory,there is no need to calibrate if no special situation. If the re-calibration is necessary,please contact the manufacture, and calibrate under the guidance by specialized person.

3.7 Maintenance and precautions of hardness tester

3.7.1 It is necessary to read carefully the usage instruction manual before the operation of the instrument in order to know the operational procedures and the precautions so as to avoid the damages to the instrument caused by the incorrect operation.

3.7.2 It is prohibited to dismount and alternate without permission all the electric

3. Installations and Regulation (Debugging)

component parts, the switches and sockets as well as their fixed positions; otherwise the instrument could malfunction and trigger accidents.

3.7.3 It is prohibited to move the sample during loading and unloading, otherwise it would damage the instrument. Only after testing force has been unloaded and the screen returns to operating page, then the sample can be rotated.

3.7.4 Turn on the power, it is necessary to reset before testing

3.7.5 The Diamond Indenter(5)

1) The diamond indenter and the indenter shaft are important parts of the instrument, and hence it is necessary to take care not to touch the indenter during the operation.

2) In order to assure the precision of the measurement, it is important to keep the indenter clean. If it is covered with grease or dust, the tip of indenter should be cleaned carefully and lightly with absorbent cotton wetted with a little alcohol (industrial use) or ether.

3.7.6 The Eyepiece(6)

1) Owing to personal difference of visions, the graduated lines observed in the vision field of the eyepiece may seem vague. And accordingly, the observer should turn slightly the Eye Guard (7) on the eyepiece so as to observe the graduated line in the vision field clearly.

2) The Eyepiece should be inserted to the bottom of eyepiece tube and keeping without any space between them, otherwise it would affect the correctness of the measurement. When testing the length of diagonal line of indentation, it is necessary to measuring the tip points of diagonal line, then turn the Eyepiece by 90° and test other a pair of tip points for diagonal lines.

3.7.7 The specimen

The surface of the specimen must be clean, as the grease or the dirt on the surface would

3. Installations and Regulation (Debugging)

affect the precision of the measurement. Please clear the specimen with alcohol or ether.

3.7.8 The measurement for Knoop Hardness (force of 1 kgf(9.8N) or less can switch between Vickers and Knoop).

1) Exchange the Indenter

Loosen the screw fixed on the Indenter (5) with a screwdriver to take the Indenter out, change the Knoop Indenter for replacement. Note the direction when assembling. The red point of the indenter should be in face to front direction, the long diagonal line of indentation (the shape of indentation is a long rhombus) should be in parallel with testing table. It may be to regulate the center of indentation in vision field after install Knoop Indenter.

2) Testing hardness value

The hardness testing method of Knoop is mainly same as that of Vickers, besides it is only required to measure the length of long diagonal line for indentation. Press the Measuring Button to confirm, then the HK hardness value will display on the screen.

4. Accessories (Packing List)

1. The main hardness tester (Including a micro Vickers indenter, a 20x objective and a 10x objective)

2. Packing list

Item	Description of Goods	Quantity
1	Large, medium, and V-shaped test benches	Each 1
2	Regulating Screw	4
3	10×Micro Eyepiece	1
4	Vickers standard block	2
5	Spare Fuses (2A)	2
6	Touch pen, U disk	Each 1
7	Level	1
8	Dust bag	1
9	Power cable	1
10	Manual	1

Mikrosize Distributors Worldwide

Coventry,UK /Warsaw,Poland/Burago di Molgora, Italy/Langgöns,Germany/
Madrid, Spain/Istanbul,Turkey/Minsk,Belarus/Moscow , Russia /Sao Paulo, Brazil/
Mexico City ,Mexico/Penang, Malaysia/Bangkok Thailand etc.....



Anhui Mikrosize Precision Instrument Co.,Ltd

Factory Producing Add: N013 Shuiku Road Shatou, Changan Town, Dongguan, China.

International Trading Office: A-4035 RuiFeng Business Expo , Wuhu City, China.

Web: www.mikrosize.com Email: mikrosize@mikrosize.com

