



iLeeb-150
Pen Type Leeb Hardness Tester
Instruction Manual



Anhui Mikrosize Precision Instrument Co.,Ltd

Add: A-4035 RuiFeng Business Expo, Wuhu City, China, 241000.

Web: www.mikrosize.com **Email:** mikrosize@mikrosize.com

Contents

1. Brief Introduction.....	1
2. Instrument Operation	7
3. Instrument Calibration.....	10
4. Maintenance and Repair.....	11
5. Appendix	12
6. Packing List	13

1. Brief Introduction

This instrument is a portable measuring instrument, which can measure the hardness of common metal materials quickly, without damage and high accuracy. It can be used in both laboratory and engineering site. Through the setting of instrument measurement conditions, it can meet the needs of many kinds of measurement. The instrument can be widely used in manufacturing, metal processing, chemical industry, commodity inspection and other testing fields. It is a necessary instrument for nondestructive hardness testing.

The instrument meets the following standards:

—— «JJG 747-1999 Leeb Hardness Tester»

—— «ASTM A956-06 Standard Test Method for Leeb Hardness Testing of Steel Products»

1.1 Features

- Simple intelligence

No key "fool" operation, direct display of the most commonly used values of Richter and Rockwell.

- Small and portable

The instrument is compact, portable and integrated without connecting cable, which improves the reliability.

- Industrial highlighted OLED display

It can also be clearly displayed in direct sunlight, which is suitable for various light conditions.

- It is born colorful

Express yourself with unique style colors and show unique personality.

- The measured value is accurate

The accuracy of the measuring circuit ensures the indication error $\pm 0.5\%$ ($H_{LD}=800$), and the repeatability of the indication value is 0.8%.

1. Brief Introduction

- Support for multiple hardness systems

HL、HV、HRA、HRC、HRB、HB、HS.

- Large capacity data storage

Unprecedented mass storage leads the technology trend. 270 groups of hardness measurement data can be saved, including average value and hardness system.

- Support "steel" materials

When the "forged steel" sample is tested with D-type impact device, Hb value can be read directly without manual check. The upper and lower limits of hardness value can be set in advance, and the alarm will be automatically out of range, which is convenient for users to test in batches.

- Anytime to recharge

USB charging, compatible with most digital products such as mobile phones

- Note: the above functional features are related to the model, please refer to the appendix information later.

1.2 Measuring Theory

Under the action of elastic force, impact the surface of the sample at a certain speed with the impact body of specified quality, and calculate the hardness value with the ratio of rebound speed and impact speed of the punch at 1 mm away from the surface of the sample. The calculation formula is as follows:

$$HL = 1000 \times VB / VA$$

Where: HL--Leeb hardness value

VB--rebound speed of impact body

VA--impact velocity of impact body

The output signal diagram of impact device is as follows:

1. Brief Introduction

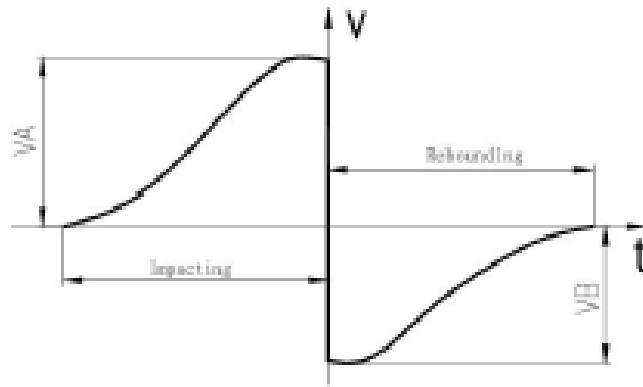

1.3 Instrument Appearance and Display



1.4 Screen Display

After the instrument is started, it will automatically enter the main display interface, as shown in the figure below:



Hardness Scale: **HL HRC** Indicates the current hardness system





Average Value: **AVE**

Direction: ↓

Power: 🔋

1. Brief Introduction

1.5 Keyboard Definition

	On/Off		Up
	Menu		Down

1.6 Specification

●Applicable Measurement Range:

Material	Hardness Scale	Impact Device	
		D	DL
Steel and Cast Steel	HRC	17.9~68.5	20.6~68.2
	HRB	59.6~99.6	37.0~99.9
	HB	127~651	81~646
	HV	83~976	80~950
	HS	32.2~99.5	30.6~96.8
Steel	HB	143~650	
CWT, ST	HRC	20.4~67.1	
	HV	80~898	
Stainless Steel	HRB	46.5~101.7	
	HB	85~655	
	HV	85~802	
GC.IRON	HRC		
	HB	93~334	
	HV		
NC, IRON	HRC		
	HB	131~387	
	HV		
C,ALUM	HB	19~164	
	HRB	23.8~84.6	
BRASS	HB	40~173	
	HRB	13.5~95.3	
BRONZE	HB	60~290	
COPPER	HB	45~315	

1. Brief Introduction

Specification

Performance Index
Impact D Testing Direction: 360 Vertical, Tilt down, Level, Slope, Vertical up)
Testing Range (170-960)HLD, (17.9-69.5)HRC, (19-683)HB, (80-1042)HV, (30.6-102.6)HS, (59.1-88)HRA, (13.5-101.7)HRB
Hardness Scale HL、HB、HRB、HRC、HV、HS
Display Resolution ±0.5%(HLD=800)
Repeatability of Indication 0.8%(HLD=800)
Display Industrial grade 128×64 graphic dot matrix OLED liquid crystal
Instrument Size 148mm×30mm×30mm
Power Rechargeable Li battery
Continuous Working Time 20 hours
Working Condition Working temperature—10-50°C; Storage temperature:-30°C-60°C; Relative humidity≤90%;
Applicable Material Steel and cast steel, alloy tool steel, stainless steel, gray cast iron, ductile iron, cast aluminum alloy, copper zinc alloy (brass), copper tin alloy (bronze), pure copper, forged steel
Main Application Fields Bearings and other parts; Failure analysis of pressure vessel, turbine motor unit and equipment; Heavy work pieces; Installed mechanical or permanently assembled parts; The test space is very narrow; Formal original records of test results are required; Material differentiation of metal material warehouse; Rapid inspection of multiple measuring parts of large workpiece

1. Brief Introduction

● Impact Device

Impact Device		D/DL
Impact energy		11mJ
Impact mass		5.5g/7.2g
Hardness of indenter:		1600HV
Indenter diameter:		3mm
Indenter material:		Tungsten carbide
Diameter		20mm
Length		86(147)/75mm
Weight		50g
Max.Hardness value of working piece		940HV
Average surface roughness of specimen Ra:		1.6μm
Min.Weight of specimen: measured directly		>5kg
Need stable support		2~5kg
Dense coupling is required		0.05~2kg
Min.thickness of specimen Dense coupling		5mm
Minimum depth of hardened layer		≥0.8mm
Ball head indentation size		
Hardness 300HV	Indentation diameter Indentation depth	0.54mm 24μm
Hardness 600V	Indentation diameter Indentation depth	0.54mm 17μm
Hardness 800HV	Indentation diameter Indentation depth	0.35mm 10μm
Applicable fields of impact device		DL type measuring slender narrow slot or hole; Type D is used for routine measurement

● Indication error and repeatability

Hardness value of standard Leeb hardness block	Indication error	Repeatability of indication
800HLD	±0.5%	0.8%

2. Instrument Operation

2.1 Sample Preparation

- During the preparation of sample surface, the influence of heating and cold working on sample surface hardness should be avoided as far as possible.
- If the measured surface is too rough, it will cause measurement error. Therefore, the tested surface of the sample must show metallic luster, and be flat, smooth and free of oil stain.
- Surface: the test surface of the sample should preferably be flat. Small support ring or special-shaped support ring shall be used for the test sample with curvature radius r less than 30mm.

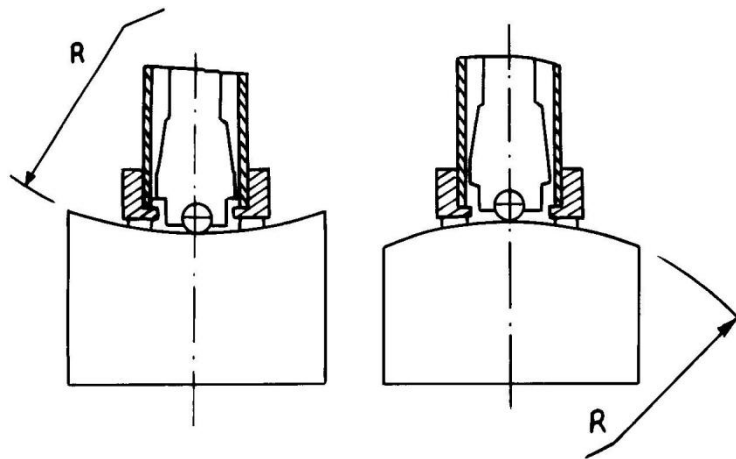

- Support of sample
 - — For heavy specimens, no support is required
 - — For the medium-sized sample, it must be placed on a flat and firm plane, and the sample must be placed absolutely stably without any shaking;
 - The sample shall have enough thickness, and the minimum thickness of the sample shall meet the requirements of Table 3.
 - For samples with surface hardening layer, the depth of hardening layer shall meet the requirements of Table 3.
- Coupling
 - — For the light sample, it must be closely coupled with the solid support, the two

2. Instrument Operation

coupling surfaces must be flat and smooth, the amount of coupling agent should not be too much, and the test direction must be perpendicular to the coupling plane;

- When the specimen is a large area plate, long rod and bending part, even if the weight and thickness are large, it may cause deformation and instability of the specimen, resulting in inaccurate test values. Therefore, the back of the test point should be reinforced or supported.
- The magnetism of the sample itself should be less than 30 Gauss.

2.2 Measuring Operation

- Power on
 - No key version: push down the loading sleeve to lock the impact body, press the release button on the upper part of the impact device, and the instrument will enter the measurement state after self inspection.
 - With key version: press the [on/off] key, the power is turned on, and the instrument enters the measuring state after self checking.
- load
 - Push down the loading sleeve to lock the impact body, and the loading is completed.
 - The supporting ring of the impact device shall be pressed on the surface of the sample, and the impact direction shall be perpendicular to the test surface.
- measure
 - Press the release button on the upper part of the impact device to test. At this time, the sample, impact device and operator should be stable, and the direction of force should pass through the axis of impact device.
 - Each measuring part of the sample is generally tested three times.
 - Read the average value of measurement as a Leeb hardness test data.

2. Instrument Operation

- Shut down

- — If there is no operation, the instrument will shut down automatically after a period of time.

- — Key version: press the [on/off] key to turn off the instrument.

- The distance between any two indentations or the distance between the center of any indentation and the edge of the sample shall comply with the following table.

Distance between two indentation centers	Distance between indentation center and sample edge
≥3mm	≥5mm

- Hardness system setting (with key version)

- — According to the applicable measurement range, select the hardness system and start the measurement.

2.3 Recharge

This machine uses rechargeable lithium battery. When the battery voltage is too low, please charge it in time, and select the charging head and USB charging cable.

When the battery voltage is too low, the instrument will automatically shut down. Whether it is turned on or not, it can be charged after connecting the charger, and the indicator light of the charging head will be on.

3.Instrument Calibration

If the measurement indication error and repeatability are too large,the standard Leeb hardness block(optional)can be used to calibrate the instrument and impact device.

Enter the calibration menu,as shown in the figure below

—With key version:press the[menu]key to enter the menu,press the[up and down]key to select"software calibration",and press the[menu]key to enter the calibration state.

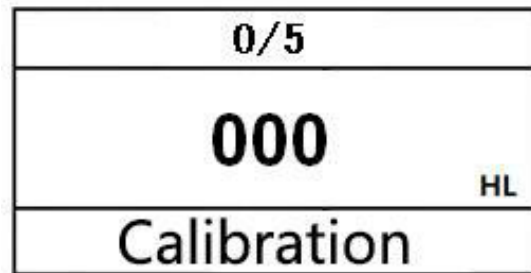

— No key version:continuously measure the air for five times to enter the calibration state.

Calibration measurement

— Five points were measured vertically and downward randomly on the Leeb hardness block to get the average value.

●Adjust the measured value according to the nominal value of standard Leeb hardness block.

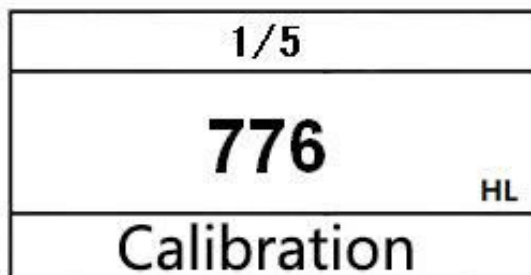

●—With key version:press the up and down key to adjust the measured value to the nominal value,and press the menu key to complete the calibration.

●—No key version:the measured value will be reduced by 1 for one time of empty measurement,and increased by 1 for one time of workpiece or hardness block measurement.After adjusting to the nominal value,there is no need to do any operation, and the calibration will be completed automatically after 5 seconds.

●The calibration range is $\pm 15HL$.

4.Maintenance and Repair

4.1Impact Device

After 1000-2000 times of use,use nylon brush to clean the pipe and impact body of the impact device.When cleaning the pipe,first screw down the support ring,and then take out the impact body.Screw the nylon brush into the pipe anticlockwise,and then pull it out. Repeat this for 5 times,and then install the impact body and support ring;

After use,the impact body should be released;

All kinds of lubricants are strictly prohibited in the impact device.

4.2Normal Maintenance Procedure

When the standard Rockwell hardness block is used for verification,if the error is greater than 2hrc,the ball head may be worn out,and the ball head or impact body shall be replaced.

When there are other abnormal phenomena in the hardness tester,please do not disassemble or adjust any fixed assembly parts.After filling in the warranty card,it will be handed over to the maintenance department of our company to implement the warranty regulations.Generally,the stay time of the instrument in our company is not more than one week.

4.3Non Warranty Spare Parts List

- 1.Shell
- 2.Impact body
- 3.Support ring
- 4.Key film
- 5.Window
- 6.Lithium battery

4.4Storage Conditions,Transportation and Precautions

During storage, keep away from vibration,strong magnetic field, corrosive medium, humidity and dust, and store at room temperature.

The transportation can be carried out under the condition of class III Highway under the condition of ensuring the original packaging.

5. Appendix

Model	Key Menu	Impactor	Parameter	Testing Material	Testing Direction
Lpad A	×	D	HL/HRC	Steel and Cast steel	
Lpad B	√	D	HL/HV/HRC /HRB/ HB/HS	Steel and cast steel /alloy tool steel /stainless steel /gray cast iron /ductile iron /cast aluminum alloy /copper zinc alloy (brass) /copper	360°
Lpad C	√	DL	HL/HV/HRC /HRB/ HB/HS	Steel and cast steel /alloy tool steel /stainless steel /gray cast iron /ductile iron /cast aluminum alloy /copper zinc alloy (brass) /copper tin alloy (bronze) /pure Copper /forged steel	360°

6.Packing List

	Item	Qty
Standard Delivery	Main Unit	1
	Supporting Ring	1
	Instruction Manual	1
	Brush	1
	Adapter	1
	Cable	1
	Instrument Case	1
Optional Delivery	Standard Test Block	1

Mikrosize Distributors Worldwide

Coventry,UK /Warsaw,Poland/Burago di Molgora, Italy/Langgöns,Germany/
Madrid, Spain/Istanbul,Turkey/Minsk,Belarus/Moscow , Russia /Sao Paulo, Brazil/
Mexico City ,Mexico/Penang, Malaysia/Bangkok Thailand etc.....



Anhui Mikrosize Precision Instrument Co.,Ltd

Factory Producing Add: N013 Shuiku Road Shatou, Changan Town, Dongguan, China.

International Trading Office: A-4035 RuiFeng Business Expo , Wuhu City, China.

Web: www.mikrosize.com Email: mikrosize@mikrosize.com

